

Electronic Steerable Beam (ESB) Traffic Signal Heads

Part of the Intelight Complete Traffic Framework



Electronically Steerable Beam traffic signal head



LED array that provides illumination and steerable beam



Optional Internal Stop Bar Detection Camera.

Easily Adjust Light Beams Without Getting up in a Bucket Truck

The Electronically Steerable Beam (ESB) traffic signal features an electronically programmable signal head with an array of LEDs as the illumination source. LEDs can be programmed to electronically steer the light beam as well as raise and lower light intensity for turning pocket signals using a Wi-Fi enabled PDA. Both vertical and horizontal viewing angles can be programmed for typical turn pockets plus restrict viewing for far side indications. The Intelight ESB signal saves hours of staff time and dramatically reduces exposure to traffic dangers. Power consumption averages 8 Watts compared to the 150 watts required by legacy incandescent programmable vehicle heads.

Key Electronic Steerable Beam Traffic Signal Head Benefits

- Provide a visibility zone of red, yellow, and green without requiring louvers or other external blocking devices
- Signal illumination is remotely programmable to desired area of visibility
- Signals are complete head replacements and part of the Intelight Complete Traffic Framework
- Reduces energy and maintenance costs by 95%

Unique Electronically Steerable Beam traffic signal features

- **100% intelligent LED traffic signal**
- **Thermally enhanced modular housing** - improves operational life
- **Ambient Light Adjustment** - signal light intensity varies automatically with changes in ambient light. No killer-greens.
- **Upgradeable design** - cost efficient future software and hardware features
- **7-year warranty** - longest in the industry

Advanced Optional Intelight ITS Platform Features

- **Embedded 4-way video cameras** - enables real time and stored color and black/white images and part of the Intelight ITS Platform
- **Battery Backup Capability** - operates directly from a 120V AC or 48V DC power source
- **Built-in communications** - power line modem with communications over existing signal wires
- **Sensors** - providing improved transportation mobility, enhanced public safety and Homeland Security features

Compliance and Approvals

Intelight meets or exceeds traditional traffic signal specifications. Independent laboratory test results of Intelight's products are available on request.

Provided By:

ECONOLITE

3360 E. La Palma Ave. | Phone: (714) 630-3700
Anaheim, CA 92806 | Fax: (714) 630-6349

www.econolite.com

ESB Traffic Signal Head Configuration

Size	12 inches (300mm)
LED Types	Red/Amber/Green: AlInGaP
LEDs per Arrow	Mask defined arrow
Lens Materials	Polymeric
Lens Description	Clear lenses standard, tinted available
Lens Configuration	Fresnel and refractive Lenses
Reflector Materials	Polycarbonate
Reflector Description	Custom parabolic
Reflector Configuration	Integrated with housing
Housing Materials	Reinforced, UV resistant polycarbonate
Gaskets	Silicone foam
Mounting	ESB horizontal and vertical stacks Arrows horizontal and vertical placements: <ul style="list-style-type: none"> • Mast arms • Top of post • Stabilized Span • Side of pole

ESB Product Overall Dimensions

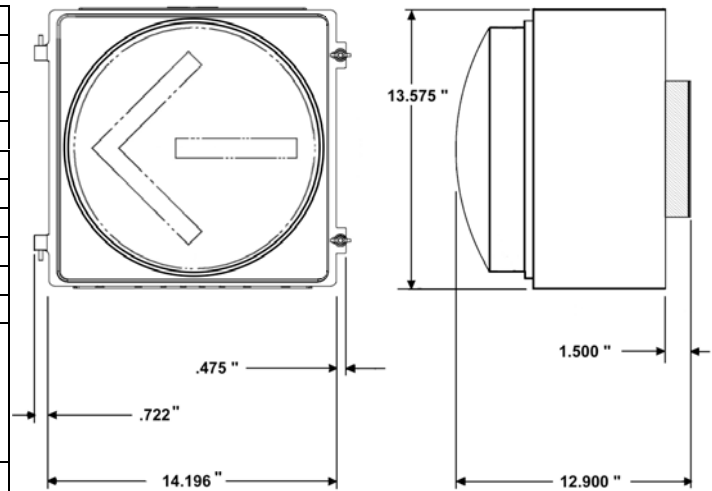

ESB Traffic Signal Head Product Features

Model Number	Description	Beam Color	Power (Watts)	Chromaticity in Dominant Wavelength (nm)	Luminosity in Candelas *
100001	Flood	Red	22**	$(0.998 - x) \leq y \leq 0.308$	339 < 30% Dimming < 50% Brighten
100001	Flood	Yellow	22**	$\{0.411 \text{ and } (0.995 - x)\} \leq y \leq 0.452$	678 < 30% Dimming < 20% Brighten
100001	Flood	Green	22**	$(0.506 - 0.519x) \text{ and } (0.150 + 1.068x) \leq y \leq (0.730 - x)$	678 < 30% Dimming < 30% Brighten
100001	Arrow	Yellow	22**	$\{0.411 \text{ and } (0.995 - x)\} \leq y \leq 0.452$	135 < 30% Dimming < 20% Brighten
100001	Arrow	Green	22**	$(0.506 - 0.519x) \text{ and } (0.150 + 1.068x) \leq y \leq (0.730 - x)$	70 < 30% Dimming < 30% Brighten

- Ambient Light Adjustment feature adjusts for external levels.
- 100% Power and all rows and columns on. Typical usage is <35% or 8 watts

ESB Operating Specifications**

Temperature Range	- 40° C to + 74° C
Voltage Range AC	80 VAC to 135 VAC / 60Hz ± 3Hz
IP Rating Unenclosed / Enclosed	IP 34 / IP 65
Power Factor	> 0.90%
Voltage Typical AC	120 VAC / 60Hz
Voltage Typical DC	48 VDC
Voltage Protection	6000 V
Voltage Conversion	AC or DC operations with the change of a single wire
Backup	Photovoltaic and standard battery backup available
Total Harmonic Distortion (THD)	< 20%
Offstate Impedance	< 1K ohm

** Specs & typical values tested under laboratory conditions, Ta= 25°C

ESB Performance Values

Functional Characteristics	Compliance
Chromaticity (Color)	ITE VTCSH-STD Part 2, Part 3
Luminous Intensity Values	ITE VTCSH-STD Part 2, Part 3
Transient Immunity	NEMA TS-2
Transient Protection	ITE VTCSH-STD Part 2, Part 3
Water/Moisture Resistance	NEMA STD 250 1991 Type IV Encl. IEC 60529
Vibration Resistance	NEMA MIL-STD-833 Test Method 2007
Electronic Noise	FCC Title 47 Sec. 15 Sub B, Class A
Dust/Solid Objects	IEC 60529
Temperature Cycling	MIL-STD 883 Test Method 1010
Temperature Resistance	NEMA
Controller Compatibility	170, 2070, NEMA TS-1, TS-2 1992
Voltage Spikes/Protection	IEEE/ANSI C62.41 Cat. C Level 2
Wiring	National Electric Code 18 AWG