



Secure Power

Uninterruptible Power Sources
83kVA-664kVA



Secure Power's microturbines generate power and heat. Use both and you'll minimize your data center's energy bills, maximize efficiency, and reduce greenhouse gas emissions.

CCHP and CHP

With Secure Power in a CCHP application, the microturbines' clean exhaust is used to drive an absorption chiller to meet your data center's air-conditioning needs. Or use Secure Power as a CHP application and the waste heat energy will support your building's heating needs.

Secure Power provides air conditioning that's virtually electricity-free and cuts operating costs. You can automatically switch between cooling and heating as needed with the advanced functionality of the Secure Power Capstone microturbines.

Secure Power CCHP and CHP solutions: Cooling when it's hot, heating when it's not and reliable, affordable power every day.



Secure Power: Cleaner and More Efficient

Traditional UPS Using Average US Power Plant Capstone CHP Capstone CCHP

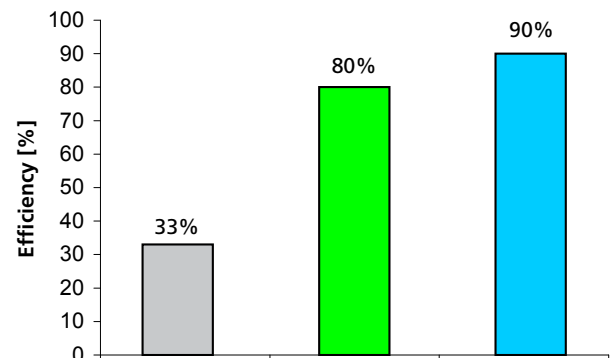
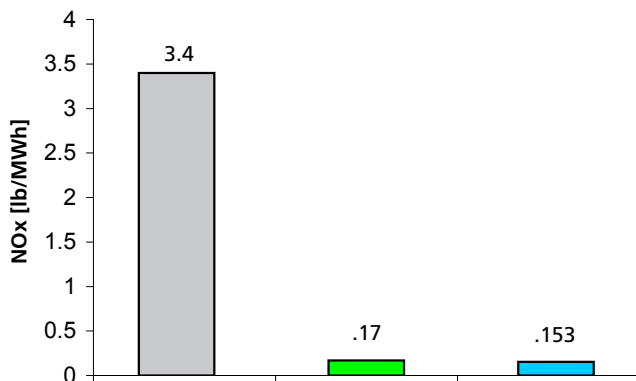

Secure Power

Capstone's Secure Power is the most reliable and affordable microturbine-powered UPS available. Ideal for mission-critical loads, Secure Power produces clean, IT-grade power that offers eight 9's of reliability. We offer two Secure Power products: **UPSource**, which offers efficient primary power that runs parallel to, yet independent of, the grid, and **Hybrid UPS**, which offers dual-conversion power electronics via three modes – High Efficiency, Standard UPS and Emergency Backup. Fuel efficiency up to 90%, minimal maintenance and no indoor floor space means low costs.



Secure Power: Microturbine-Powered UPS

- Clean-and-green (ultra-low exhaust emissions)
- 99.999999% availability
- IT-grade power
- Up to 90% fuel efficient
- Multi-fuel capable
- Multiple power modules – no single point of failure
- Low maintenance – only 1 moving part, no coolants/lubricants
- No indoor floor space required (and associated costs)
- Expands to match load growth
- Reduces energy cost
 - CHP – use waste heat for building heating
 - CCHP – use absorption chiller for air conditioning

Reliable power when and where you need it. Clean and simple.

Hybrid UPS

- Dual-conversion power electronics
- 3 operating modes
 - High Efficiency
 - Standard UPS
 - Emergency Backup

The Hybrid UPS Solution

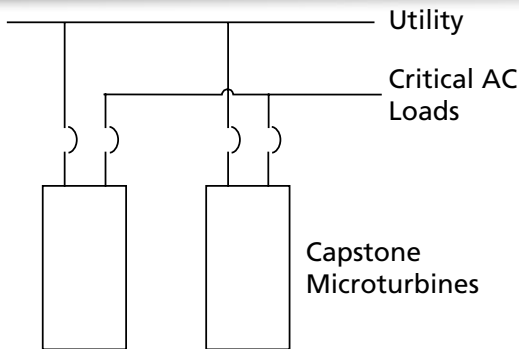

In the Hybrid UPS solution, the utility is normally connected to the critical bus through the microturbines. Power for the critical loads can be supplied from the microturbine, from the utility, or a combination of both.

How It Works

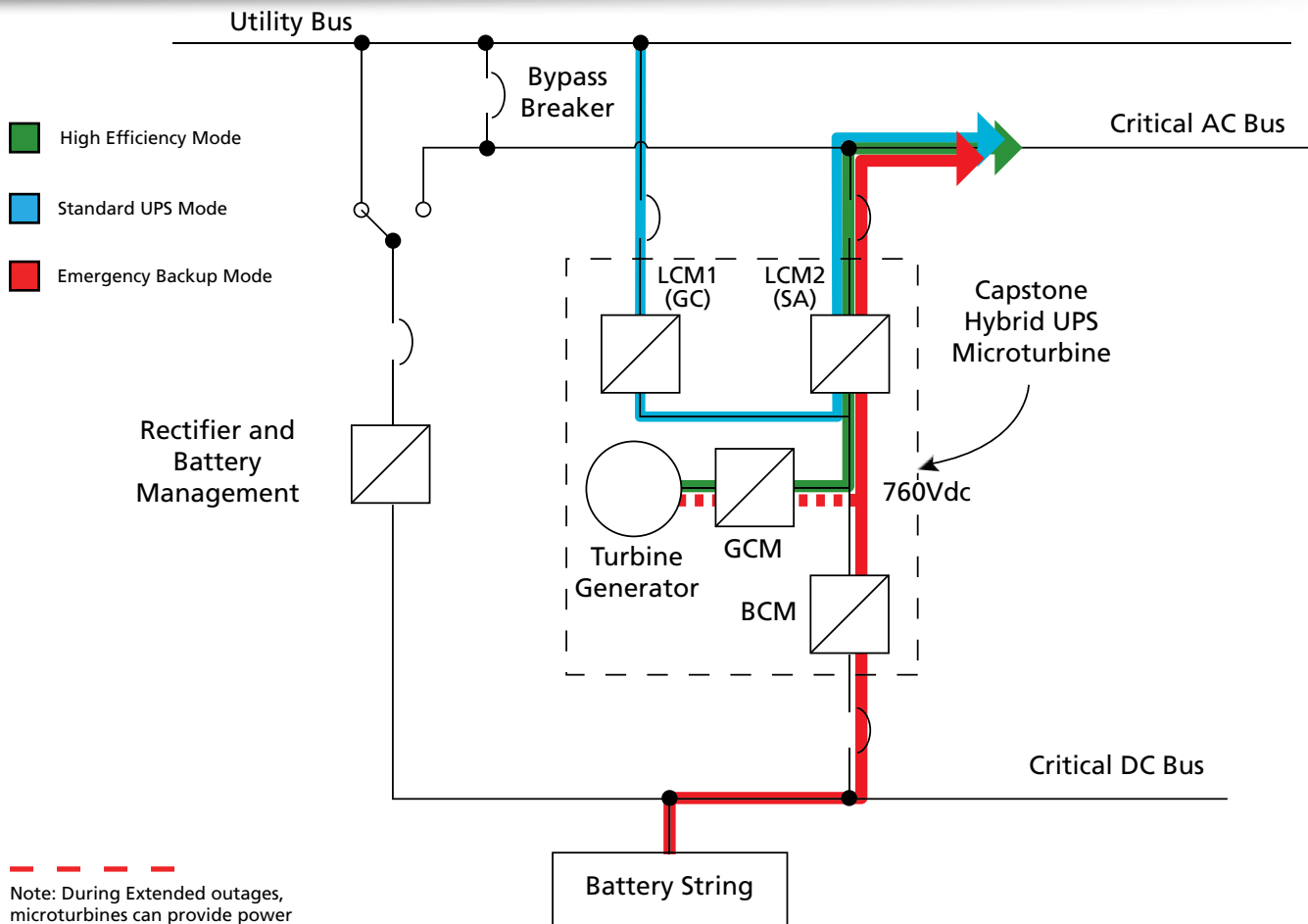

UPSource

- Microturbines are primary power
- Operates independent of utility 24/7
 - Stays synchronized with utility
 - Seamless transfer to utility grid when needed

The UPS Solution

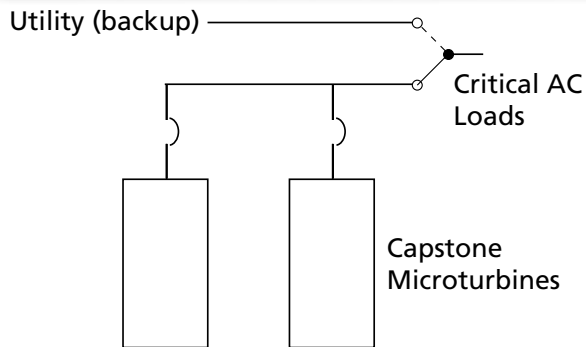

In the UPSource solution, microturbines provide primary power to the critical loads. The system will seamlessly switch to utility power as the backup in the unlikely event that the microturbines are not able to support the load.

How It Works

- Prime Power Mode
- Emergency Backup Mode

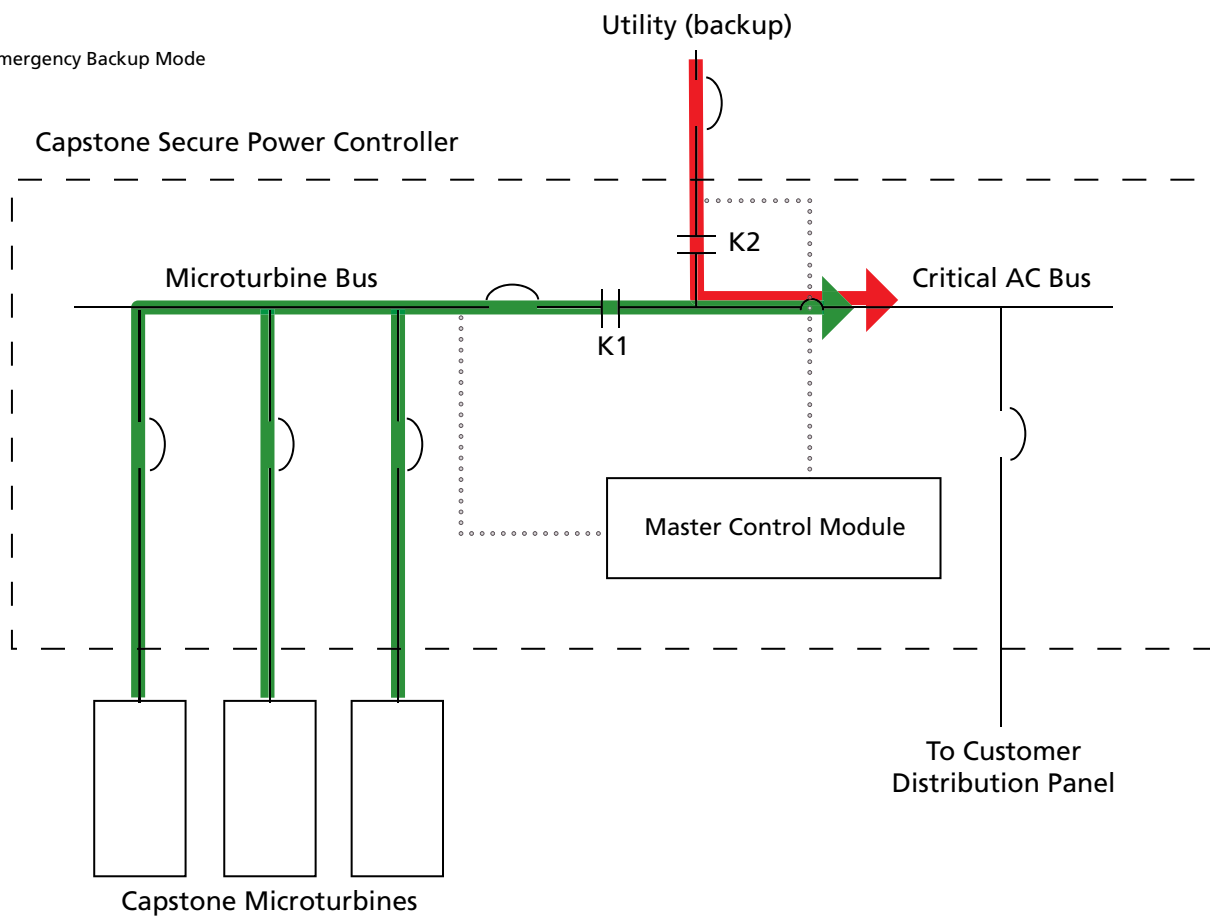

Electrical Characteristics	UPS-80	UPS-250	UPS-580
kVA/kW ⁽¹⁾	83/65	249/195	581/455
Expandable to	332/260	664/520	664/520
Max Output Current ⁽²⁾	125A RMS	750A RMS	875A RMS
Voltage	400 to 480 VAC		
Electrical Service	3-phase, 4 wire		
Frequency	50/60 Hz		
Electrical Output Type	IGBT Inverter for all models		
Current THD	5%, IEEE 519 compliant		

Fuel Characteristics ⁽⁴⁾	UPS-80	UPS-250	UPS-580
Natural Gas (HHV)	30.7 MJ/m ³ to 47.5 MJ/m ³ (825 to 1,275 BTU/scf)		
Fuel Inlet Pressure	1.4 - 34 kPa gauge (0.2 - 5 psig)		
Fuel Flow ⁽²⁾	842 scft/hr	1684 scft/hr	3368 scft/hr

Available Certifications	UPS-80	UPS-250	UPS-580
UL 1741/IEEE 1547	X	X	X
UL 2200	X	X	X
CE	X	X	X
Outdoor Rating	X	X	X

NO _x Emissions ⁽³⁾	
Standard Models	9 ppmvd (19 mg/m ³)
CARB Certified Models	4 ppmvd (8 mg/m ³)

(1) Nominal full power performance at ISO condition: 59°F, 14.696 psia, 60% RH

(2) Values are for base system (no expansion)

(3) Exhaust emissions for standard natural gas at 39.4 MJ/Nm³ (1,000 BTU/scf) (HHV) corrected to 15% O₂

(4) Contact Capstone for alternate fuels

Specifications are not warranted and are subject to change without notice.

